

Instruction Manual

Model GA-72Cd Magnetic Locator

Manufactured By
Schonstedt Instrument Company

**100 Edmond Road
Kearneysville, WV 25430**

**(304) 725-1050
Fax (304) 725-1095**

**Web: www.schonstedt.com
E-mail: info@schonstedt.com
Made in USA**



A TRADITION IN PRECISION

Seattle 425-771-7776 | Tacoma 253-922-6087
Portland 503-641-3388 | Salt Lake City 801-878-9763
Las Vegas 702-586-1152 | St. George 702-586-1152
Boise 208-369-4388

www.KukerRanken.com

Preface

The GA-72Cd Magnetic Locator is a product of over 60 years' experience in producing the world's finest flux-gate magnetometers and magnetic detectors for aerospace, military and civilian applications. The GA-72Cd incorporates the knowledge obtained from manufacturing under the most rigid quality control standards. The heart of the GA-72Cd is its patented Schonstedt HeliFlux® magnetic field sensors. These sensors, acknowledged to be the world's finest, make possible the unequalled performance of our locators.

June 2017

Table of Contents

SECTION I: Operation	
Introduction	3
Turn-on, Sensitivity and Volume Settings	4
Battery Level Indication	4
Audio Output Selection.....	5
Search Procedure.....	6
SECTION II: Application Notes	
Basic Signal Patterns	7
Strongly Magnetized Markers.....	8
Correct Stake Orientation is Important	9
Locating Manholes, Septic Tanks and Well Casings.....	9
Locating Objects under Snow or Water	10
Locating and Tracing Barbed Wire.....	11
Searching Areas along a Chain Link Fence	11
Locating Valve Boxes.....	12
Locating Cast-Iron Pipes.....	12
Locating Steel Drums	13
Locating Ordnance and Weapons.....	13
Additional Applications.....	15
Other Notes	15
SECTION III: Data Logger Output	16
SECTION IV: Maintenance	
Replacement of Batteries	17
Troubleshooting Guide	18
SECTION V: Service and Shipping Information	18
SECTION VI: Specifications	19
SECTION VII: Warranty Information	20
SECTION VIII: Repair Parts	21

Important Notice

Schonstedt believes the statements contained herein to be accurate and reliable; however, their accuracy, reliability, or completeness is not guaranteed.

Schonstedt's only obligation shall be to repair or replace any instrument proven to be defective within seven years of purchase. Schonstedt shall not be responsible for any injury to persons or property, direct or consequential, arising from the use of any instrument.

SECTION 1: OPERATION

Introduction

The GA-72Cd Magnetic Locator detects the magnetic field of ferromagnetic objects. It responds to the difference in the magnetic field between two sensors that are spaced approximately 14 inches apart. This difference is referred to as the “signal strength” throughout this manual and is represented in the instrument by an audio tone and visual indication of both signal strength and polarity. While most objects can be located using either the audio or visual indication, simultaneous use of both will help you pinpoint a target and determine its orientation.

Figure 1 illustrates an application in which the locator is used to detect an iron marker used for property line identification. As shown, the magnetic field of the iron marker is stronger at Sensor A than it is at Sensor B. As a result, the frequency of the audio signal is higher than the idling frequency, 40 Hz, which exists when the field strength is the same at both sensors. This stronger signal also causes the digital indication to peak in either the positive or the negative direction when the audio signal is at its highest frequency.

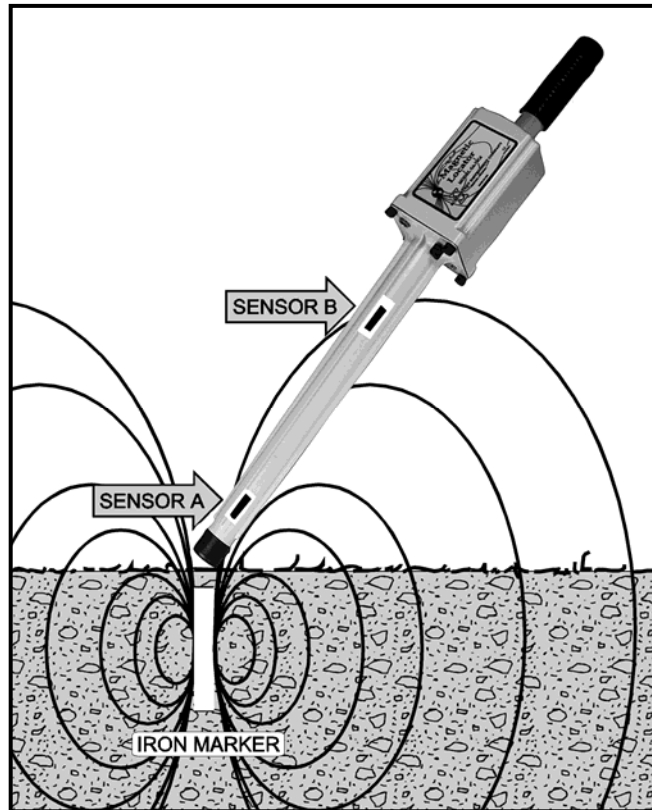

Figure 1: Detecting Magnetic Field of an Iron Marker

When shipped, the locator is set to provide an audio signal that is heard as long as the instrument is turned on. If desired, you can change this setting to an audio signal that is heard only when the instrument is within detection range of an object (refer to page 5 of this manual for instructions).

Turn-On, Sensitivity and Volume Settings

Turn on the GA-72Cd by rotating the On/Off-Sensitivity control knob clockwise to position 1. This sets the sensitivity to what is referred to as the Normal Range (the L meter indication). Sensitivity can be increased by rotating the Sensitivity control clockwise to select M, H, or XH settings (as indicated on the meter's GAIN display). Adjust the Volume control for the desired audio output level.

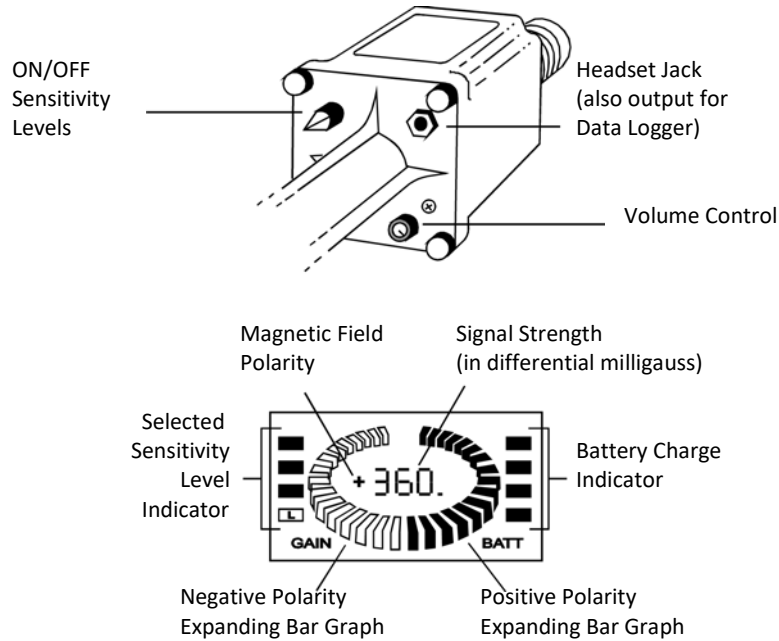

Figure 2: Control and Meter Indications

Battery Level Indication

The meter's BATT indication displays the batteries' voltage level. When all four segments are black, the voltage level is between 100% and 25% (up to 40 hours of operation with intermittent usage). As the voltage decreases, the number of black segments decreases. Battery life varies with usage and the ambient temperature. Cold temperatures reduce battery life. Low temperatures may result in only two or three segments being black; this could be temporary and all segments will change back to black as the temperature increases.

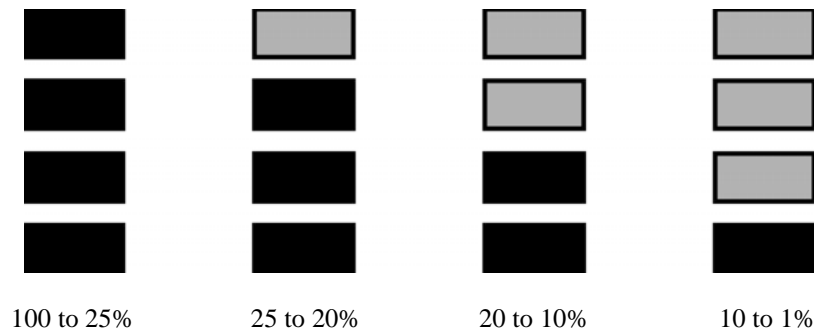

Figure 3: Battery Voltage Status Indications

Audio Output Selection

All GA-72Cd's are shipped from the factory with the Audio Output Switch set to "B"; this setting provides an audio signal that is always present. If you prefer to not hear a signal until the locator is within detection range of a target, set the switch to "A".

Audio Signal with Output Switch set to "A"

No audio signal is heard until the GA-72Cd comes within detection range of a ferromagnetic object. The locator will increase in volume over the object. It will decrease in volume and turn off when the locator is moved out of range.

NOTE: If you put the GA-72Cd down without turning the Sensitivity/Power switch to Off, the "power-on monitoring feature" (designed to conserve battery life) will initiate a beeping audio-alert signal after 15 seconds.

Audio Signal with Audio Output Switch set to "B"

As you move the GA-72Cd across a ferromagnetic object, the 40 Hz idling signal, which is always present, increases in frequency, peaks when the locator is directly over the object and then decreases to 40 Hz.

Regardless of which switch setting, the indication of signal strength and the polarity on the meter will always peak (positive or negative) when the locator is directly over a ferromagnetic object.

As shown in Figure 4, the cover must be removed to change the setting of the Audio Output Switch.

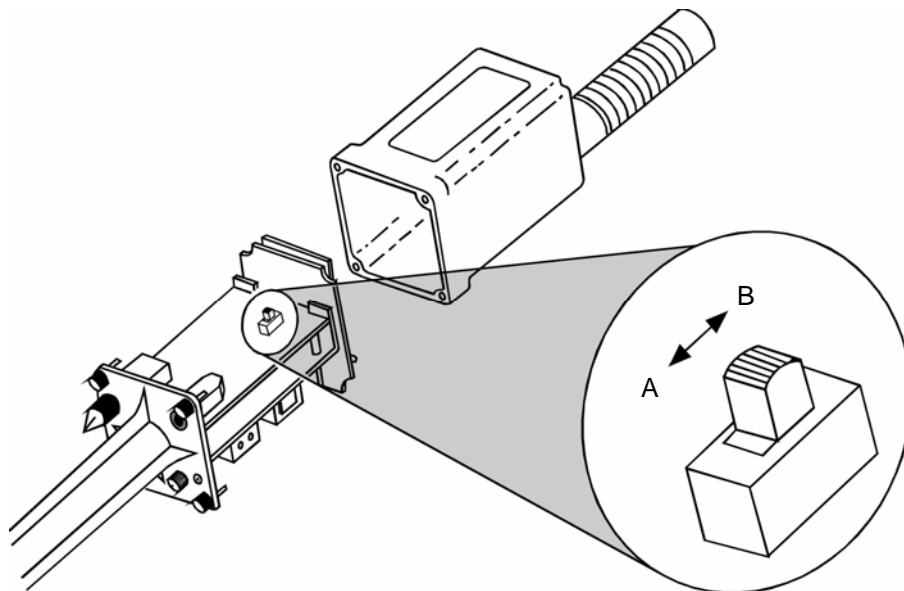

Figure 4: Location of Audio Output Switch

Search Procedure

Set the On/Off-Sensitivity control for L and grasp the locator as illustrated in Figure 5. Because the upper sensor is located near where the locator is usually held, wrist watches may produce unwanted changes in the audio signal and in the meter indications. Remove your wrist watch or hold the locator in the other hand. Keep the locator away from your shoes; shoes may contain magnetic material.

To obtain the maximum area of coverage, the locator should be swept from side to side. When the locator comes within range of an iron object, the audio signal will peak, the bar graph will expand positive or negative, and the digital readout will peak.



Figure 5: Searching With the Locator

When the GA-72Cd is positioned directly over a vertical pipe, the audio and digital indications will peak. The expanding bar graph and digital readout may display either a positive or a negative level.

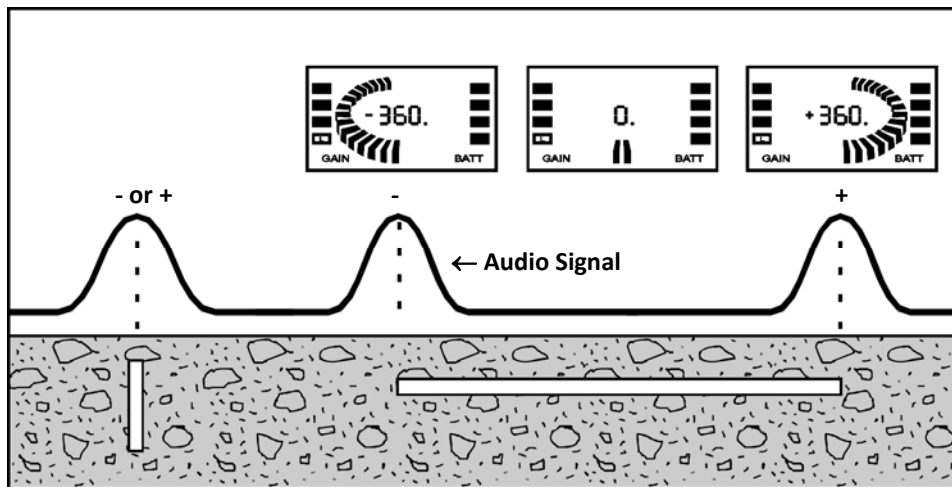

Figure 6: The Meter's Polarity Indications Help to Determine Target Orientation

The audio signal, bar graph and digital indications peak over each end of a horizontal pipe. One end is positive; the other end is negative. This will help you to distinguish between two vertical pipes or one horizontal pipe. Usually two vertical pipes buried in close proximity will produce digital indications with the same polarity.

APPLICATION NOTES

Basic Signal Patterns

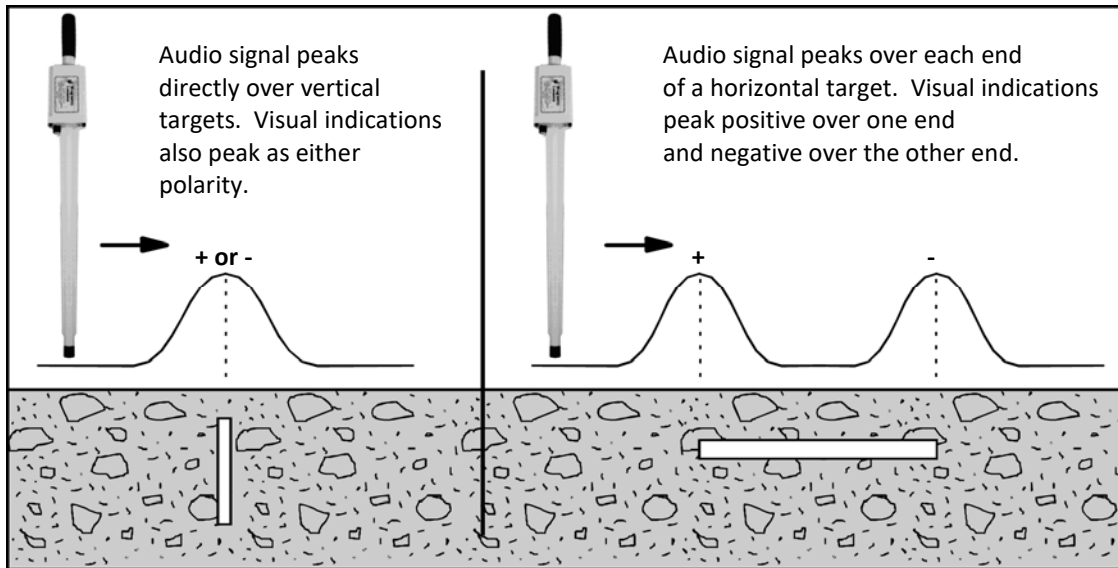

Figure 7: Signals from Vertical and Horizontal Targets

After you have detected the presence of a target, hold the locator vertically and slowly move it back and forth in an “X” pattern while observing the digital readout. The value of the number will be highest when the locator is directly over a vertical target or over the ends of a horizontal target. The “X” pattern, as shown in Figure 8, is ideal for pinpointing small objects. By using this technique, a 1-1/4 inch PK nail buried up to 8 inches can be precisely located.

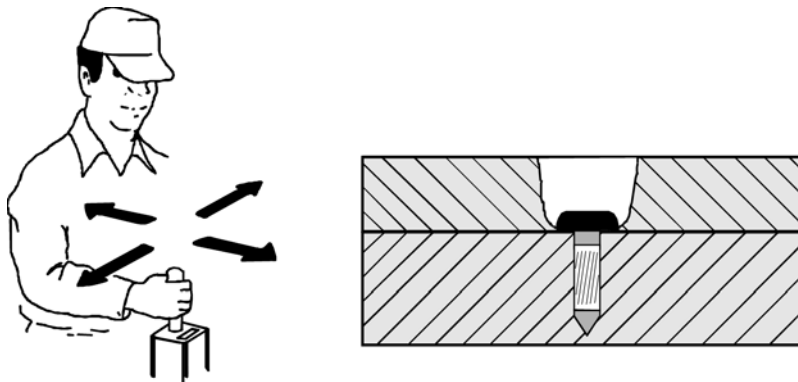

Figure 8: “X” Pattern provides Precision Locating

If you are looking for a corner marker and detect two more signals in the same general area, raise the locator several inches above the ground or reduce the sensitivity setting. Any signal that disappears when the locator is held higher or when the sensitivity is decreased is probably coming from a shallow target. As shown in Figure 9, the signal from a rusty bolt or other small item decreases much faster with distance than the signal from a larger target, such as a 18-inch length of 3/4 rebar that can be located at depths up to 7 feet.

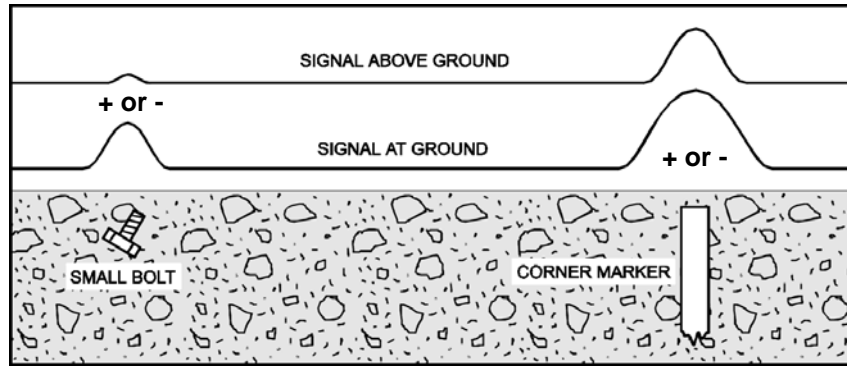

Figure 9: Raising the Locator Eliminates Unwanted Signals

Strongly Magnetized Markers

A strongly magnetized marker that is at or near the surface will provide a weaker indication on both sides of the marker, and this can be mistaken for the actual marker.

The heavy line in Figure 10 represents the increase and decrease in the audio and digital indications as you move the locator over a marker. Between points **A** and **B**, the signals increase slightly and then decrease. Just beyond **B**, the signals increase rapidly, peak directly over the marker, and then decrease at point **C**. From **C** to **D**, the signals increase and decrease again. Therefore, if you do not move the locator completely across the marker, you may assume that the weaker indication on either side of the marker is its location.

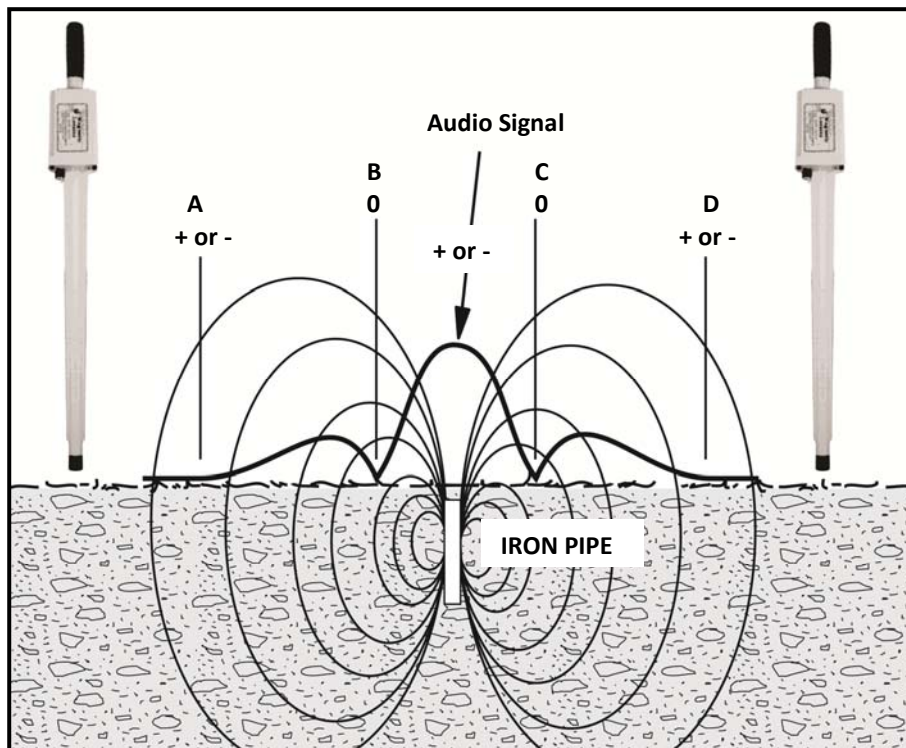

Figure 10: Signal Pattern from a Strongly Magnetized Marker

The two weaker indications on both sides of the actual marker occur because the locator is extremely sensitive to the magnetic field components parallel to its long axis. At point B and C, the field is perpendicular to the locator so no peak audio or digital indications are produced.

When Placing Stakes, Correct Orientation is Important

For checking purposes, the orientation of the pin relative to the locator is shown in Figure 11. Check the pin with one orientation. Then rotate the pin 180°. The orientation that gives the largest reading is the one that should be used. This reading will be positive in the Northern Hemisphere and negative in the Southern Hemisphere (Australia, New Zealand, etc.)

An iron pin has two types of magnetization. One is the magnetization induced by the Earth's magnetic field. The induced magnetization is always downward in the Northern Magnetic Hemisphere and produces a positive output no matter which end of the stake is driven into the ground. The other type of field is the permanent magnetization that is fixed to the pin. For maximum detection, the stake should be driven into the ground so that the permanent magnetization is in the same direction as the induced magnetization.

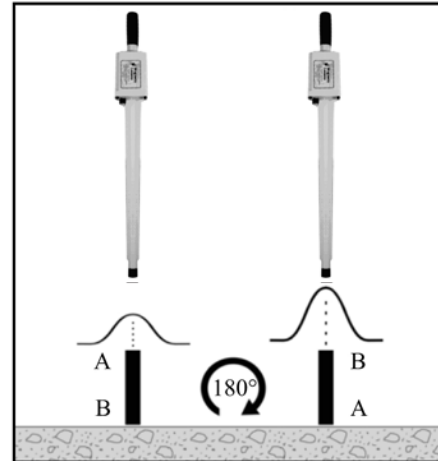

Figure 11: Checking a Stake's Orientation

Locating Manholes, Septic Tanks and Well Casings

The magnetic field is strongest at the edge of a shallow manhole cover. You can easily trace the edges of covers near the surface. The locating depth for manhole covers ranges up to 8 feet.

The great length of a well casing provides a strong field at the surface that makes it easy to locate casings buried up to 15 feet deep.

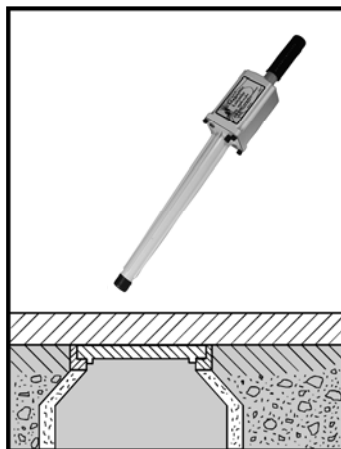

Figure 12: Locating Manhole Covers

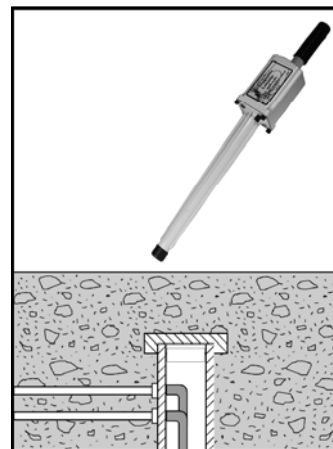

Figure 13: Locating Water Well Casings

The GA-72Cd can be used to precisely locate the metal handles or reinforcing bars on septic tank covers at depths up to 4 feet.

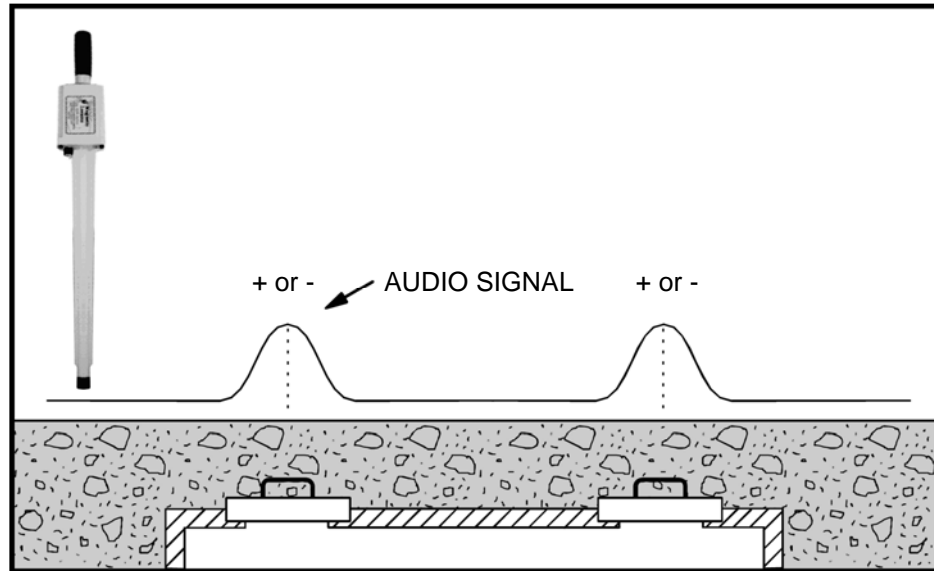

Figure 14: Signal Patterns Provided by Septic Tank Covers

Locating Objects under Snow or Water and Tracing Barbed Wire

The locator can be used in snow or in flooded areas - just keep the electronic unit out of the snow or water.

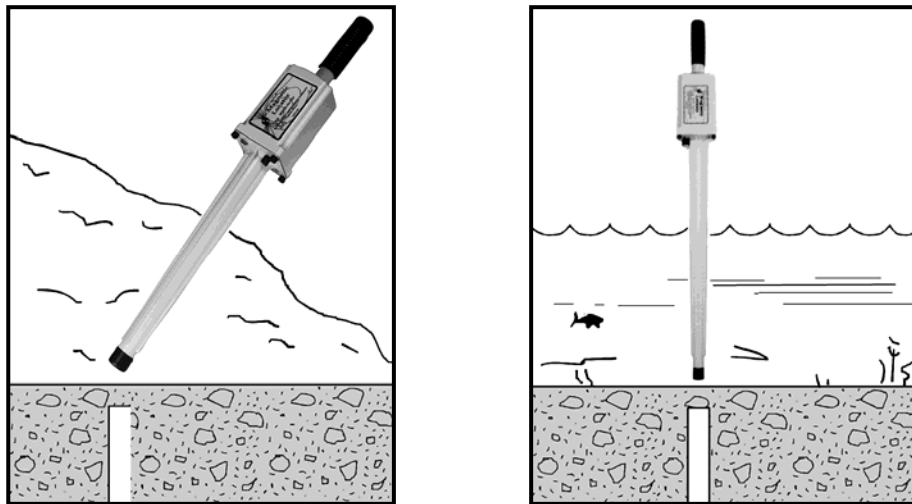

Figure 15: Locating Objects under Snow or Water

Locating and Tracing Barbed Wire

You can often trace barbed wire from old fence lines buried just beneath the surface. Even if the wire is only a trail of rust, it can still be detected near the surface. Tip the locator a little lower than usual (but not parallel with the ground).

Examine trees for bench marks and bits of embedded barbed wire. Then hold the locator parallel to the direction of the wire.

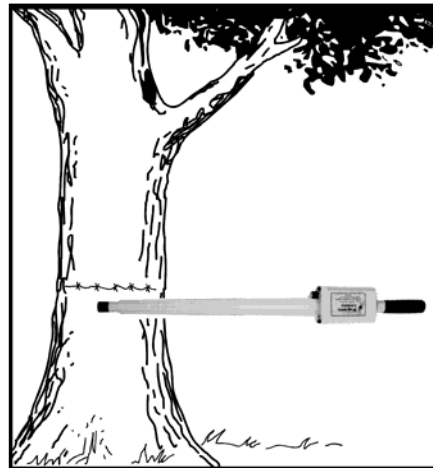
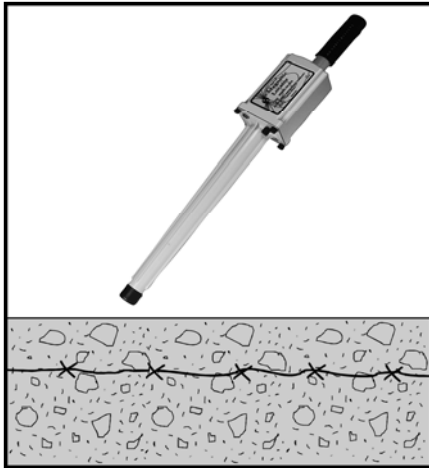

Figure 16: Tracing Barbed Wire from Old Fence Lines

Searching Areas along a Chain Link Fence

Searching in the vicinity of a chain link fence requires a reduced sensitivity setting and some control over the orientation of the locator. As illustrated in Figure 17, position the locator horizontally with its long axis perpendicular to the fence. This ensures that the upper sensor is kept away from the fence.

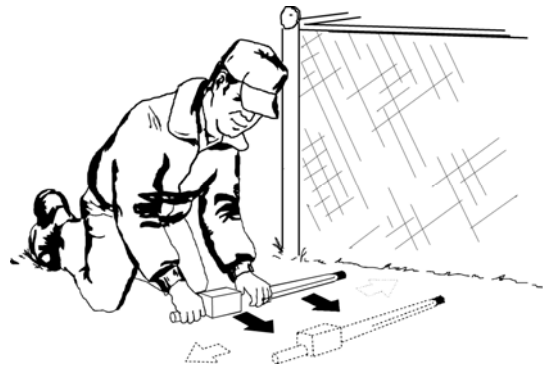

Figure 17: Searching in the Vicinity of a Chain Link Fence

Perform the search by slowly moving the locator forward along the fence while also moving it to the right and to the left. As you move forward, this technique will allow you to search an area several feet wide. Listen for an abrupt drop in the signal (as shown by the null in Figure 18) that will occur when the lower sensor, located 1-5/8 inches from the end of the locator, is directly over the stake. Any variation in the position of the locator will produce an abrupt rise in the frequency of the signal.

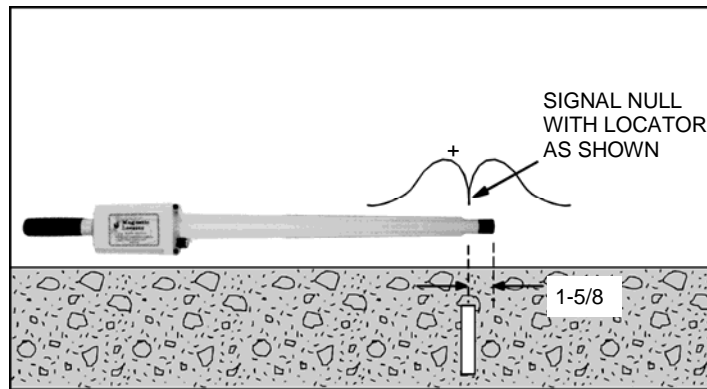

Figure 18: Placement of Locator while Searching along a Chain Link Fence

Locating Valve Boxes

Both the valve and its casing, when iron, provide strong magnetic fields that make them easy to locate. Plastic enclosures containing magnets are easily located at depths of 6 feet or more.

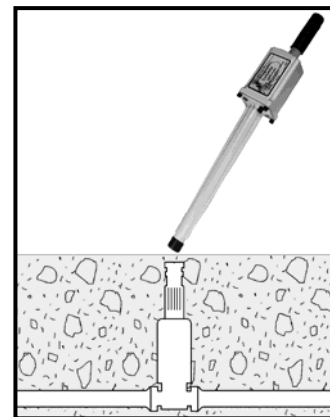

Figure 19: Locating Valve Boxes and Casings

Locating Cast-Iron Pipes

As illustrated in Figure 20, cast-iron pipes produce the strongest magnetic signals at their joints.

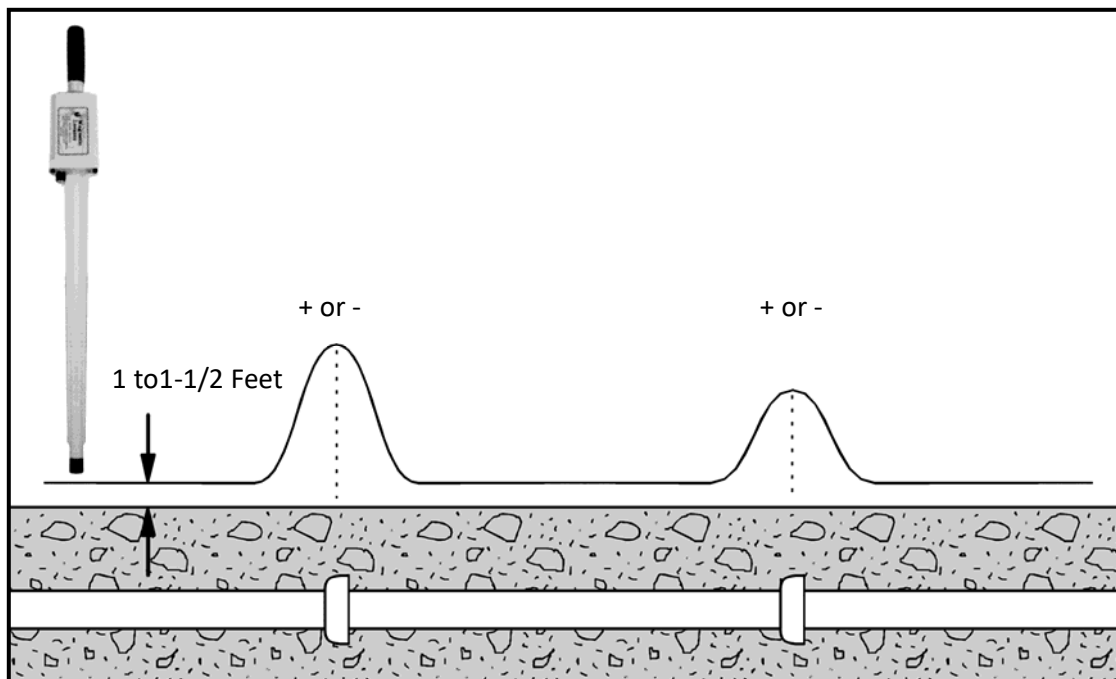

Figure 20: Signal Patterns Provided by Cast-Iron Pipes

The initial search should be performed as follows:

1. Set the Sensitivity control for maximum (XH indication).
2. Hold the locator vertically and approximately 1 to 1-1/2 feet above the surface.
3. Walk without turning or tilting the locator.
4. Mark the locations where the maximum signal levels occur.
5. Return to an area of maximum signal strength and hold the locator several inches above the surface. The sensitivity will probably have to be reduced during this second pass. Four-inch pipes can be located at depths up to 8 feet.

Locating Steel Drums

As shown in Figure 21, the GA-72Cd's signal pattern will vary depending on the vertical or horizontal orientation of the drum and how deep it is buried. A 55 gallon drum can be located at depths up to 8 feet.

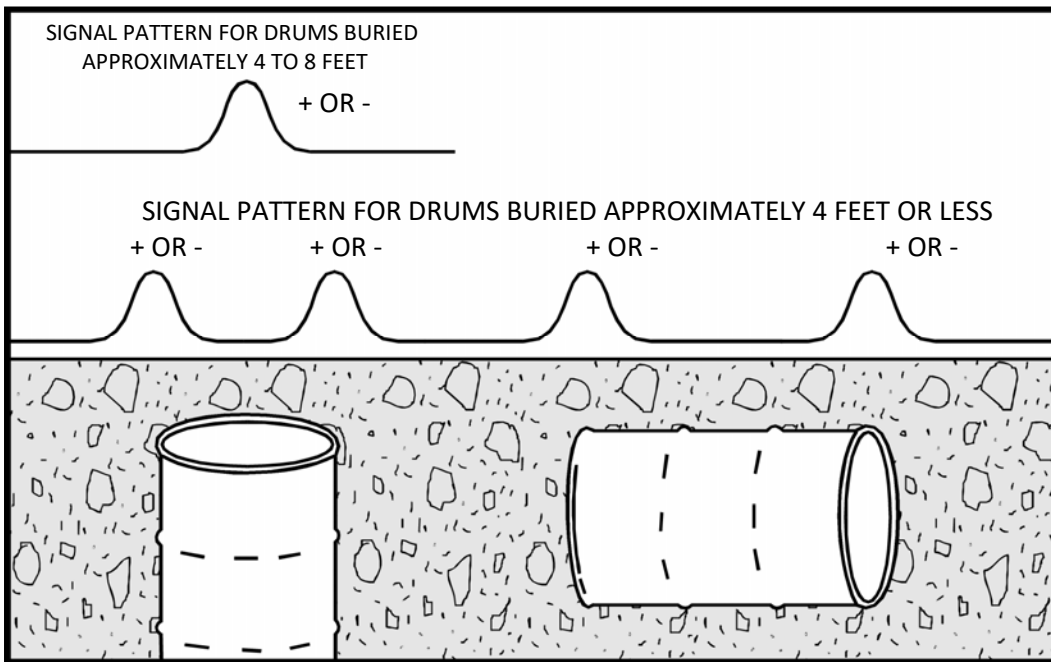

Figure 21: Signal Patterns Provided by Steel Drums

Locating Ordnance and Weapons

The versatile, lightweight, cost-effective GA-72Cd is also designed to aid EOD technicians and law enforcement officers during area search operations.

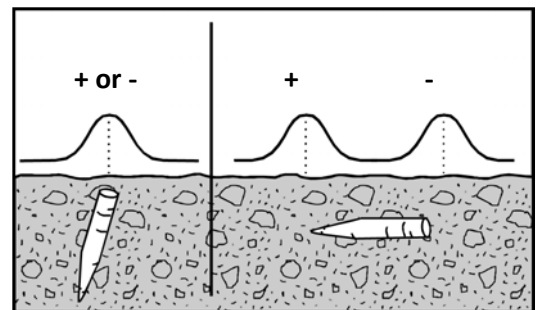

Figure 22: Basic Signal Patterns from Vertical and Horizontal Targets Help to Determine Target Orientation

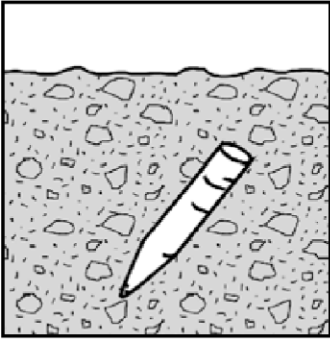

Figure 23: A 175mm Projectile can be located up to 4 feet deep.

Figure 24: An 81mm Mortar can be located up to 12 inches deep.

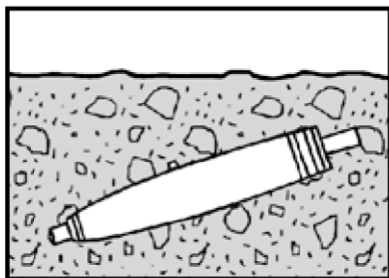
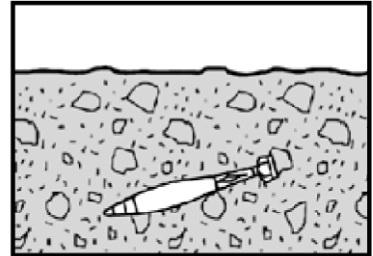

Figure 25: MK81 Low Drag Bombs can be located up to 7 feet deep.

Figure 26: A hunting knife under water can be located in up to 16 inches of silt.

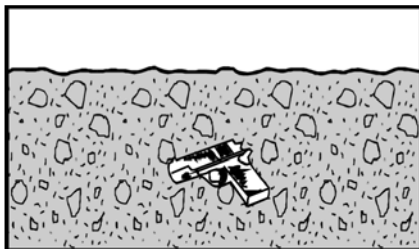
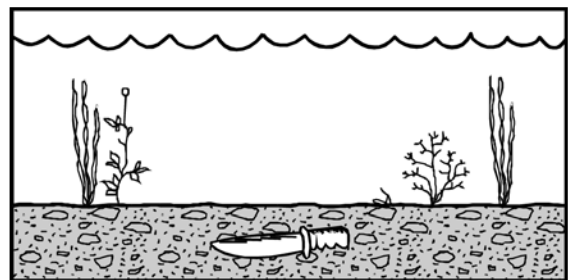

Figure 27: A discarded hand gun can be located up to 12 inches deep.

Additional Applications

1. The military and many local and state police departments use the GA-72Cd to detect buried ordnance and discarded weapons.
2. People drilling in an area where hazardous materials might be encountered should use the GA-72Cd to search the area prior to drilling.

Other Notes

1. A burbling sound indicates the presence of an energized power line. This will not influence the meter indication unless associated with a magnetic structure.
2. The instrument will not respond to non-ferrous metals such as gold, silver, copper, brass and aluminum.

DATA LOGGER OUTPUT

The headset jack also provides an analog output signal for input to a data logger. This +/-4 volt signal varies in proportion to signal strength and is accessible by wiring a standard stereo plug.

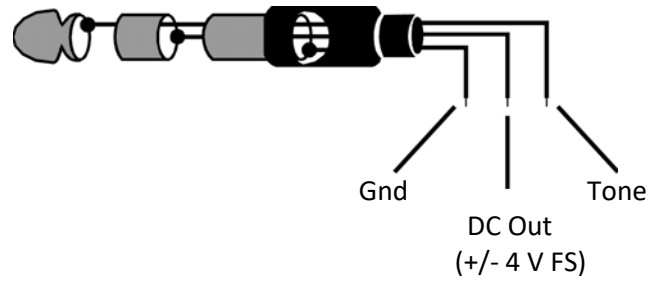

Figure 28: Stereo Plug Connections for Analog Output Signal

MAINTENANCE

The GA-72Cd is designed and built to give trouble-free operation. Normally, maintenance is limited to the occasional replacement of the batteries. In the event a malfunction does occur, refer to the Troubleshooting Guide on page 18.

Replacement of Batteries

The GA-72Cd is powered by two 9-Volt alkaline batteries. Access to the batteries is obtained by loosening the four captive screws and removing the electronics cover (as shown in Figure 29).

It is recommended that you purchase spare batteries for this unit. When you use the spare batteries, replace them as soon as possible so that you will never be without batteries in the field.

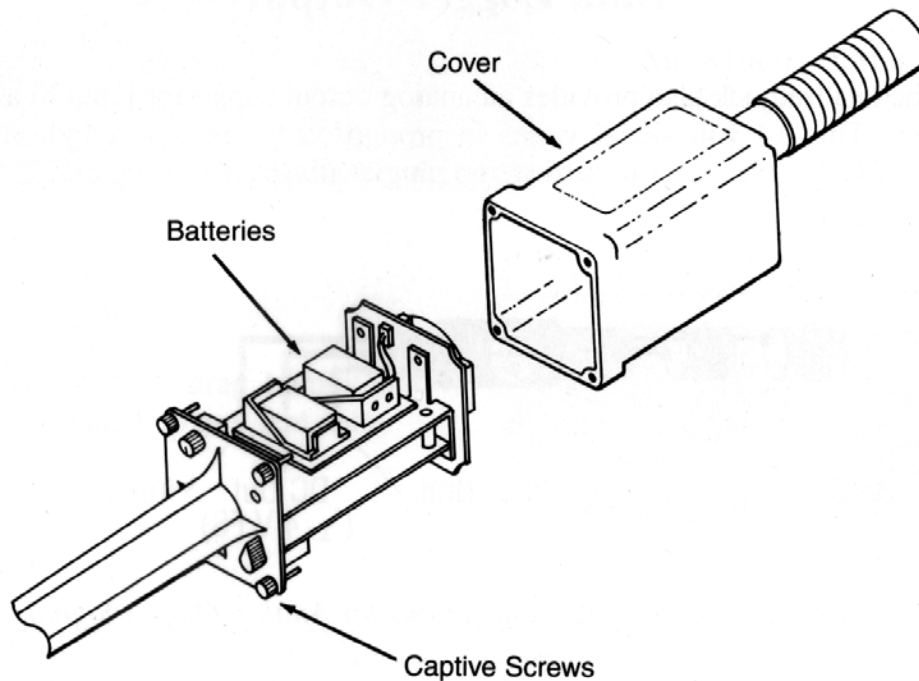

Figure 29: Exploded View of the Electronic Unit Cover

Troubleshooting Guide

Symptoms	Possible Cause	How to Check	How to Fix
Dead	Dead Batteries	Replace	-----
	Batteries not making contact	Check for contact corrosion	Clean contacts
	Battery leakage	Remove	Return unit to factory
Intermittent	Batteries not making good contact	Check for corrosion	Clean contacts
Uncontrollable screaming	Weak batteries	Replace	-----

SERVICE INFORMATION

If your locator needs service, please return it to the factory with the following information: Name, Address, Telephone and Fax Numbers, Email Address, Where Purchased, Date of Purchase, and Description of Trouble(s). An estimate will be provided prior to service work being done. See shipping information below:

FOR SERVICE OR REPAIR
 Please ship locator (in its case) to:

Schonstedt Instrument Company
 100 Edmond Road
 Kearneysville, WV 25430

SPECIFICATIONS

(Specifications subject to change without notice)

Input Power: Supplied by two alkaline 9-V batteries**

Battery Life: 40 Hours (intermittent usage)

Output:

Audio

Output Option Signal increases or decreases in volume
Switch at "A" with gradient-field intensity

Output Option Signal increases or decreases in frequency
Switch at "B" with gradient-field intensity

Visual Digital readout expanding bar graphs
indicate polarity (positive or negative) and
relative strength of the magnetic field

Battery Check: BATT 4-segment LCD

Weight: Approximately 2.5 lbs. (1.14 kg)

Operating Temperature: -13° to 140°F (-25° to 60°C)

Overall Length: 34.5 in. (87.6cm)

Waterproof Length: 21 in. (53.3cm)

Nominal Sensor Spacing: 14 in. (35.6cm)

Construction: Rugged, all solid state

***Units prior to SN: 339698 it is recommended to use Lithium batteries. Using Alkaline batteries in these units will produce a magnetic field that will impact performance of the locator (especially when set to the H or XH sensitivity range).*



This device complies with part 15 of the FCC Rules. Operation is subject to the following two conditions: (1) this device may not cause harmful interference, and (2) this device must accept any interference received, including interference that may cause undesired operation.



Application of Council Directive(s):
2004/108/EC

Standard(s) to which Conformity is Declared:
EN 61000-6-1:2001, EN61000-4-2, EN61000-4-3, EN 61000-6-3:2004,
EN55022:1998 with Amendment A1:2000 (CISPR-22)

LIMITED WARRANTY

Schonstedt Instrument Company (Schonstedt) warrants each product of its manufacture to be free from defects in material and workmanship subject to the following terms and conditions. The warranty is effective for 7 years* after the shipment by Schonstedt to the original purchaser. Please complete the warranty registration card and send back to Schonstedt Instrument Company.

Schonstedt's obligation under the warranty is limited to servicing or adjusting any product returned to the factory for this purpose and to replacing any defective part thereof. Such product must be returned by the original purchaser, transportation charges prepaid, with a description of the defect in writing. If the fault has been caused by misuse or abnormal conditions of operation, repairs will be billed. Specifically, this warranty does not cover product that has been subject to inundation by fire, water or other liquid intrusion, or units that have been damaged or compromised due to repair, alteration or modification by anyone other than an authorized repair representative. Prior to a repair being performed by Schonstedt, a cost estimate will be submitted and no work will be completed until authorized by the customer. Batteries are specifically excluded under the warranty and should be addressed to the manufacturer of batteries in question.

Schonstedt shall not be liable for any injury to persons or property or for any other special or consequential damages sustained or expenses incurred by reason of the use of any Schonstedt product.

* For Military & EOD applications, the warranty is 1 year.

GA-72Cd Repair Parts

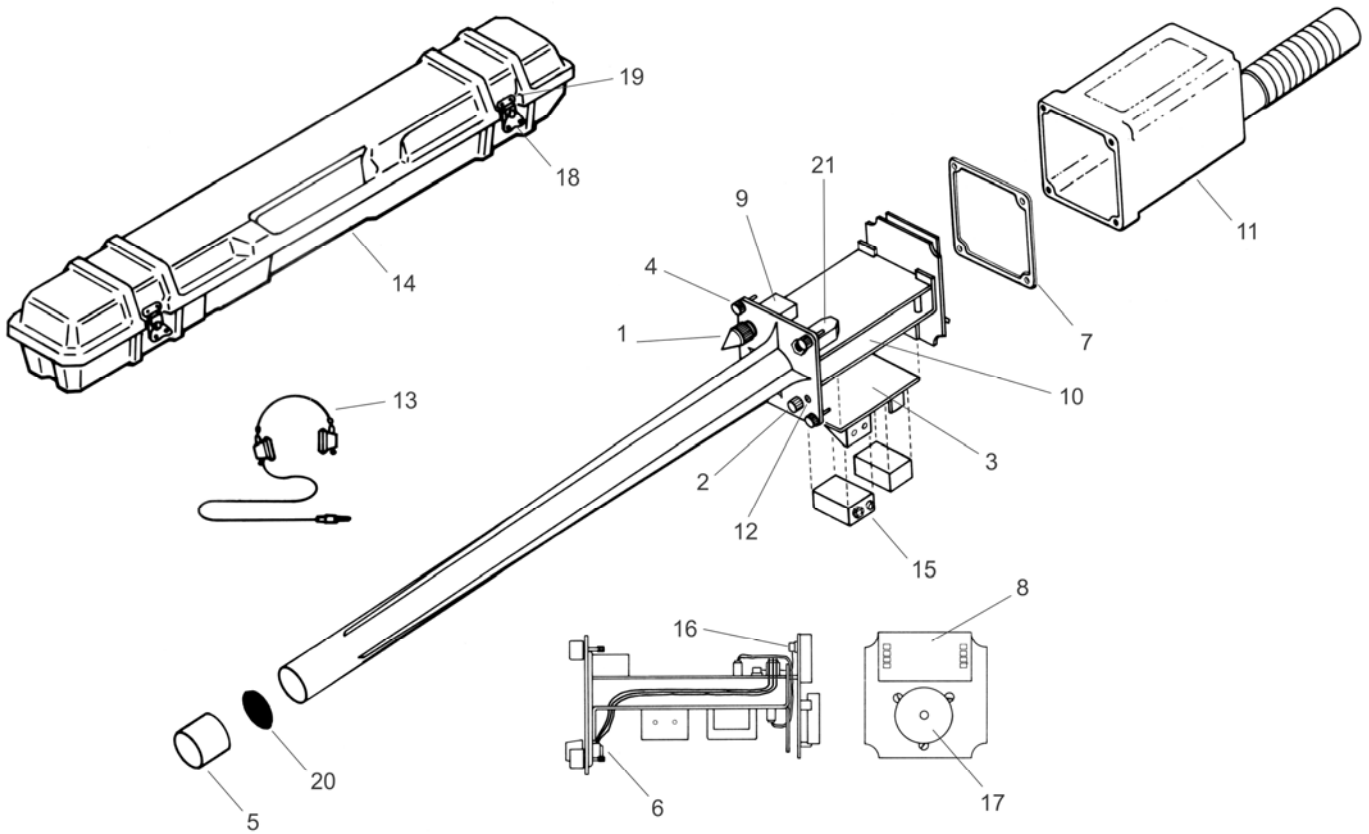

Item No	Part Number	Description
1	K20015	Knob, Pointer
2	K20013	Knob, Round
3	208306	Battery Board Assy with Cable
4	208282	Captive Screw (4 Req'd)
5	SS208195	Tip, Crutch
6	208345	Potentiometer Assembly
7	208323	Gasket, Base
8	IC8511000487*	LCD / Meter
9	S35080*	Switch, On/Off/Sensitivity
10	208317	Battery Chassis Assembly
11	208348	Cover & Handle Assembly
12	SMVIN6C500W-NP	Screw, #6-32 x 1/2" (2 Req'd)
13	H30006	Headset (Optional)
14	302145	Case, Carrying
15	B11013	9V Alkaline Battery (2 Req'd)
16	208349	Interface Cable Assembly
17	B15002*	Buzzer, Piezo
18	L55002-1	Latch
19	L55002-2	Latch Keeper
20	207220	End Cap
21	J10014*	Jack, Headset

* Requires soldering to pc board