

Instruction Manual

Model GA-52Cx Magnetic Locator

Manufactured By
Schonstedt Instrument Company
100 Edmond Road
Kearneysville, WV 25430
(304) 725-1050
Fax (304) 725-1095

Web: www.schonstedt.com
E-mail: info@schonstedt.com

Made in USA

Preface

The GA-52Cx Magnetic Locator is a product of over 60 years' experience in producing the world's finest flux-gate magnetometers and magnetic detectors for aerospace, military and civilian applications. The GA-52Cx incorporates the knowledge obtained from manufacturing under the most rigid quality control standards. The heart of the GA-52Cx is its patented Schonstedt HeliFlux™ magnetic field sensors. These sensors, acknowledged to be the world's finest, make possible the unequaled performance of our locators.

February 2017



A TRADITION IN PRECISION

Seattle 425-771-7776 | Tacoma 253-922-6087
Portland 503-641-3388 | Salt Lake City 801-878-9763
Las Vegas 702-586-1152 | St. George 702-586-1152
Boise 208-369-4388

www.KukerRanken.com

Table of Contents

SECTION I: OPERATION		
Introduction	3	
Turn-On, Volume and Sensitivity Settings	4	
Search Procedure	4	
SECTION II: APPLICATION NOTES		
Basic Signal Patterns	5	
Strongly Magnetized Markers.....	6	
Locating Manholes, Septic Tanks and Well Casings.....	7	
Locating Objects under Snow or Water	8	
Locating and Tracing Barbed Wire.....	8	
Searching Areas along a Chain Link Fence	9	
Locating Valve Boxes.....	10	
Locating Cast-Iron Pipes.....	10	
Locating Steel Drums	11	
Additional Applications.....	12	
Other Notes	12	
SECTION III: MAINTENANCE		
Replacement of Batteries	13	
Troubleshooting Guide	14	
SECTION IV: SERVICE INFORMATION.....		15
SECTION V: SPECIFICATIONS.....		15
SECTION VI: PARTS DIAGRAM		16
SECTION VII: LIMITED WARRANTY.....		17

Important Notice

Schonstedt believes the statements contained herein to be accurate and reliable; however their accuracy, reliability or completeness is not guaranteed.

Schonstedt's only obligation shall be to repair or replace any instrument proven to be defective within seven years of purchase. Schonstedt shall not be responsible for any injury to persons or property, direct or consequential, arising from the use of any instrument.

SECTION I: OPERATION

Introduction

The GA-52Cx magnetic locator detects the magnetic field of ferromagnetic objects. It responds to the difference in the magnetic field between two sensors that are spaced approximately 20 inches apart. This difference is referred to as the “signal strength” throughout this manual and is represented in the instrument by an audio tone.

Figure 1 illustrates an application of the GA-52Cx locator in which it is used to detect an iron marker used for property line identification. As shown, the magnetic field of the iron marker is stronger at sensor A than it is at sensor B. This creates a signal strength that is larger than zero (which would occur when the field strength is the same at both sensors).

The audio response of the GA-52Cx is designed so that the frequency of the audio tone increases as the detected signal strength increases. As a result, the frequency of the audio output is higher than the idling frequency that exists when the signal strength is approximately zero.

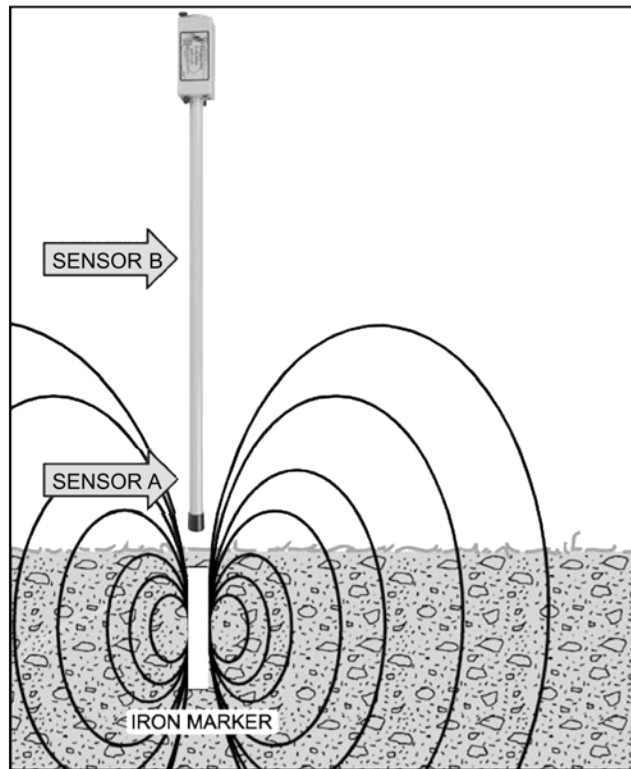

Figure 1: Detecting Magnetic Field of an Iron Marker

Turn-On, Sensitivity and Volume Settings

Set the On-Off/Sensitivity Control to position 2 and adjust the Volume Control until the idling tone reaches a desired level. The sensitivity of the unit can be increased (to detect smaller objects at greater depth) or decreased (to detect larger objects at smaller depths) by adjusting the On-Off/Sensitivity Control. Setting the Sensitivity Control to position 2 provides what is referred to as the “Normal Operating Range.” Positions 3 to 5 increase the sensitivity; position 1 decreases the sensitivity.

The locator can be oriented in any direction without producing a significant change in the frequency of the tone from its idling frequency.

When using headphones, the Volume Control has no impact on the output level of the audio signal.

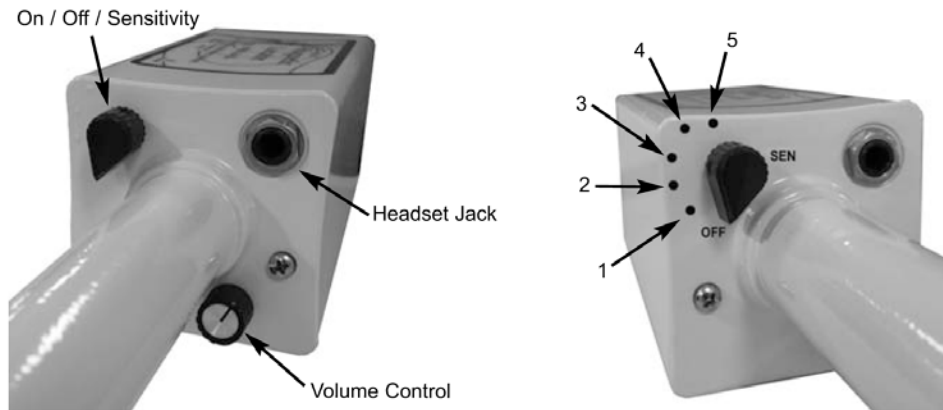

Figure 2: Sensitivity Set for Normal Range (position 2)

Search Procedure

Turn the instrument on, set the sensitivity control to position 2 (Normal Range), and grasp the locator as illustrated in Figure 3. Because the upper sensor is located near where the locator is usually held, wrist watches may produce unwanted changes in the tone's frequency. Remove your wrist watch or hold the locator in the other hand. Keep the locator away from your shoes since they may contain magnetic material.

To obtain the maximum area of coverage, the locator should be swept from side-to-side. When the locator comes within range of an object, you will hear an increase in the frequency of the output signal.



Figure 3: Searching with the Locator

SECTION II: APPLICATION NOTES

Basic Signal Patterns

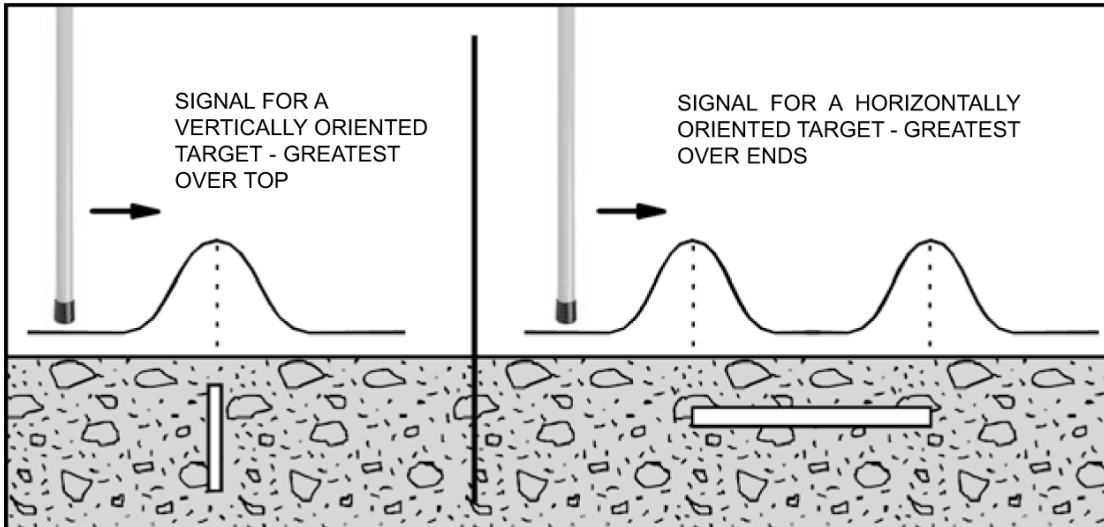

Figure 4: Signals from Vertical and Horizontal Targets

After you have detected the presence of a target, hold the locator vertically and slowly move it back and forth in an "X" pattern while listening to the audio response. The audio peak will occur when the locator is directly over a vertical target, or it will occur over the ends of a horizontal target. The "X" pattern, as shown in Figure 5, is ideal for pinpointing small objects. By using this technique, a 1-1/4 inch PK nail buried up to 12 inches can be precisely located.

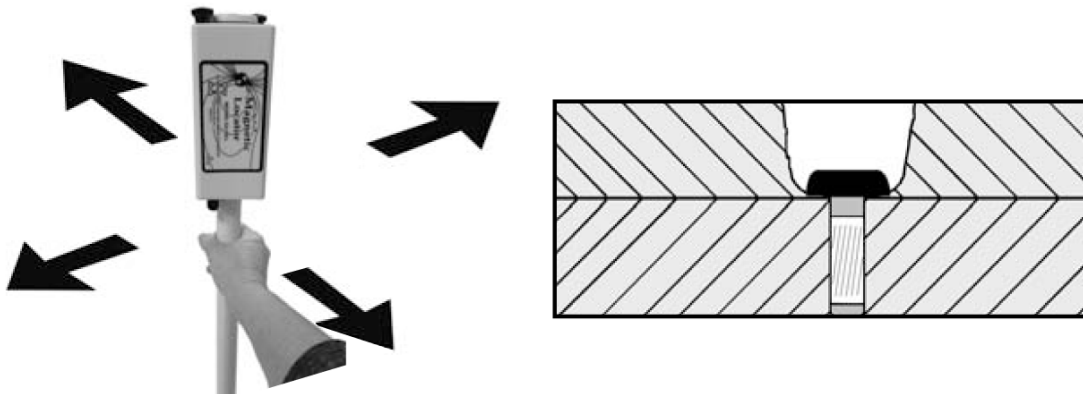

Figure 5: "X" Pattern Provides Precision Locating

If you are looking for a corner marker and detect two or more signals in the same general area, raise the locator several inches above the ground or decrease the gain setting. Any signal that disappears when the locator is held higher or the gain is decreased is probably coming from a smaller target. As shown in Figure 6, the signal from a rusty bolt or other small item decreases faster with distance than the signal from a larger target, such as an 18-inch length of 3/4 inch rebar that can be located at depths up to 9 feet.

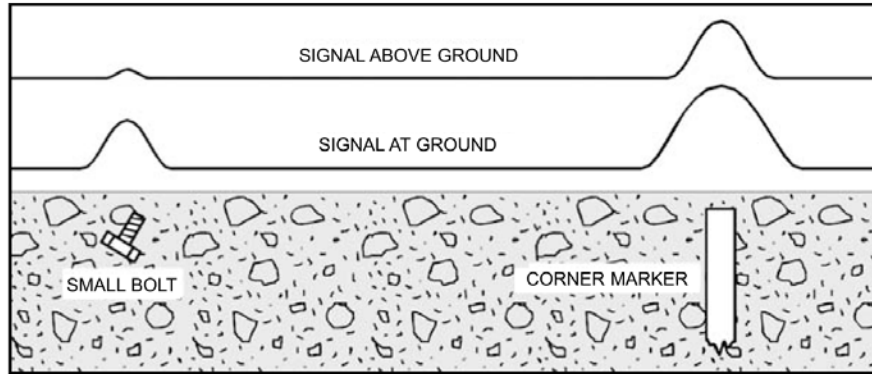

Figure 6: Raising the Locator Eliminates Unwanted Signals

Strongly Magnetized Markers

A strongly magnetized marker at or near the surface may provide location information that is misleading.

The heavy line in Figure 7 represents the variations in tone frequencies when the locator is moved over the marker. When moving the instrument from A to B, the frequency of the tone increases and then decreases suddenly at B. From just beyond B the frequency of the tone increases sharply, becomes very high directly over the marker and decrease just before reaching C. From C to D the pattern is the reverse of that from A to B. It is obvious that the locator must enter the B-C region. Otherwise the marker might be assumed to be between A and B, or C and D.

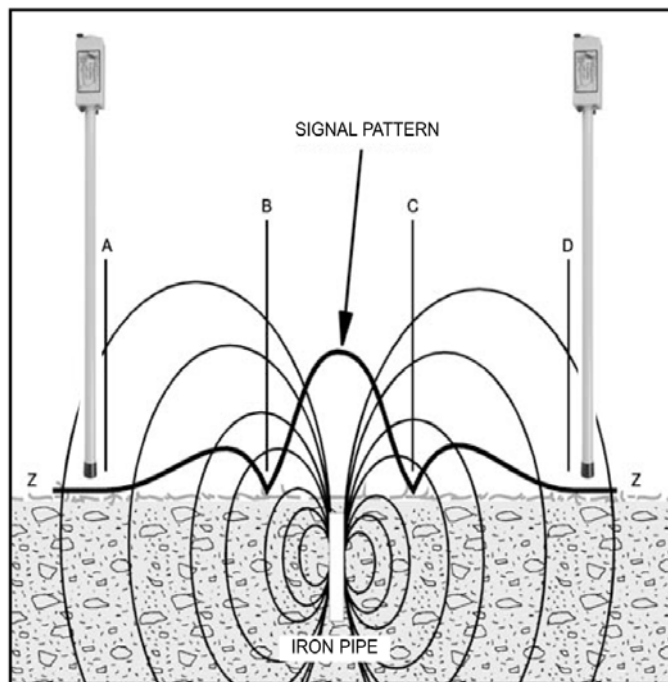

Figure 7: Signal Pattern from a Strongly Magnetized Marker

This phenomenon is explained by the fact that the locator is sensitive to the magnetic field components parallel to its long axis. At points B and C the field is perpendicular to the locator so no high frequency is produced at these points.

Locating Manholes, Septic Tanks and Well Casings

The magnetic field is strongest at the edge of a shallow manhole cover. You can easily trace the edges of covers near the surface. The locating depth for manhole covers ranges up to 10 feet.

The great length of a well casing provides a strong field at the surface that makes it easy to locate casings buried up to 18 feet deep.

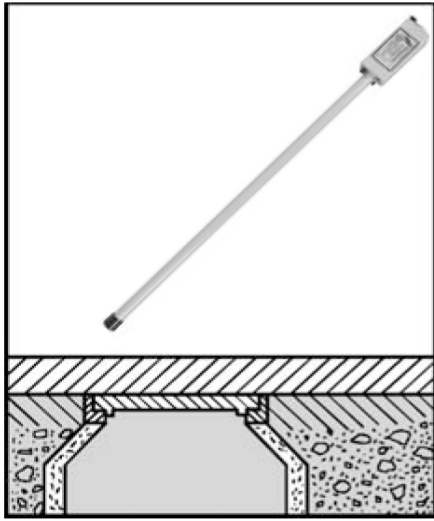

Figure 8: Locating Manhole Covers

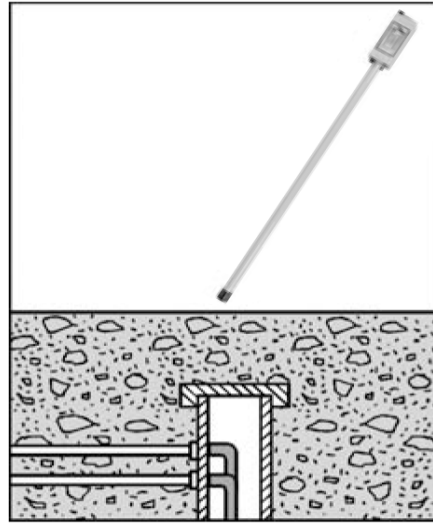

Figure 9: Locating Water Well Casings

The GA-52Cx can be used to precisely locate the metal handles or reinforcing bars on septic tank covers at depths of up to 4 feet.

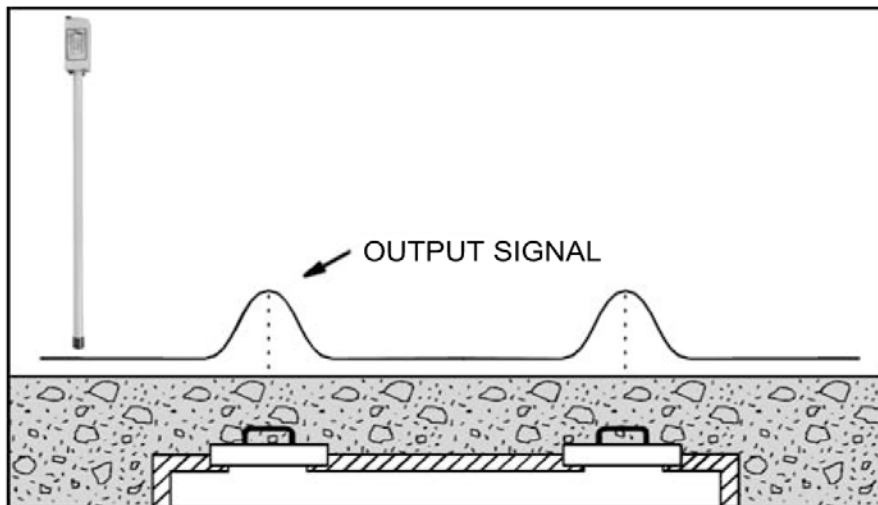

Figure 10: Signal Pattern Provided by Septic Tank Covers

Locating Objects under Snow or Water

The locator can be used in flooded areas, but keep the electronic unit out of the water.

Snow poses no problem. Thrust the locator into the snow as deep as necessary to locate the target.

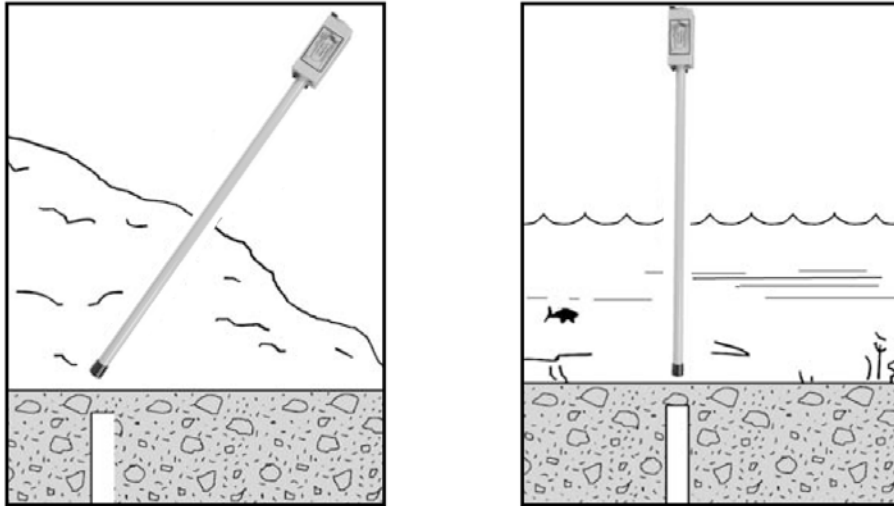

Figure 11: Locating Objects under Snow or Water

Locating and Tracing Barbed Wire

You can often trace barbed wire (from old fence lines) buried just beneath the surface. Even if the wire is only a trail of rust, it can still be detected near the surface. Tip the locator a little lower than usual (but not parallel with the ground).

First, examine trees for bench marks and bits of embedded barbed wire. Then hold the locator parallel with the direction of the wire.

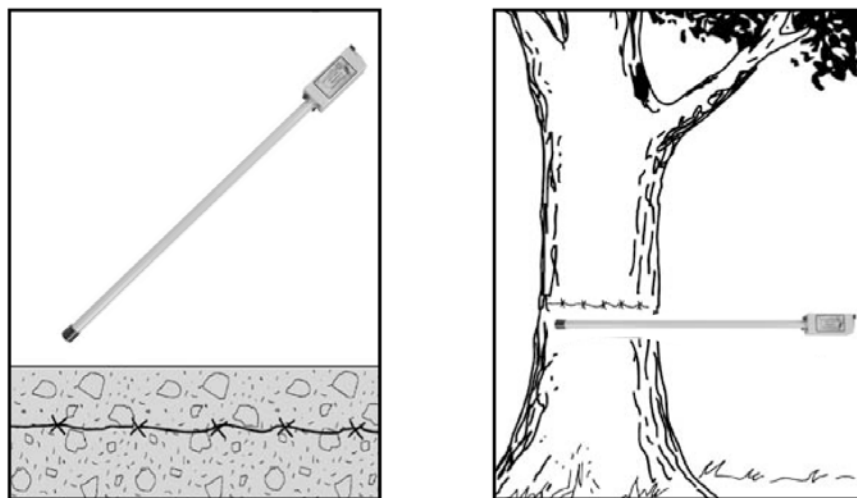

Figure 12: Tracing Barbed Wire from Old Fence Lines

Searching Areas along a Chain Link Fence

Searching in the vicinity of a chain link fence requires a reduced sensitivity setting and some control over the orientation of the locator. As illustrated in Figure 13, position the locator horizontally with its long axis perpendicular to the fence. This ensures that the upper sensor is kept away from the fence.



Figure 13: Searching in the Vicinity of a Chain Link Fence

Perform the search by slowly moving the locator forward along the fence while also moving it to the right and to the left. As you move forward, this technique will allow you to search an area several feet wide. Listen for an abrupt drop in the signal (as shown by the null in Figure 14) that will occur when the lower sensor, located 1-5/8 inches from the end of the locator, is directly over the stake. Any variation in the position of the locator will produce an abrupt rise in the frequency of the signal.

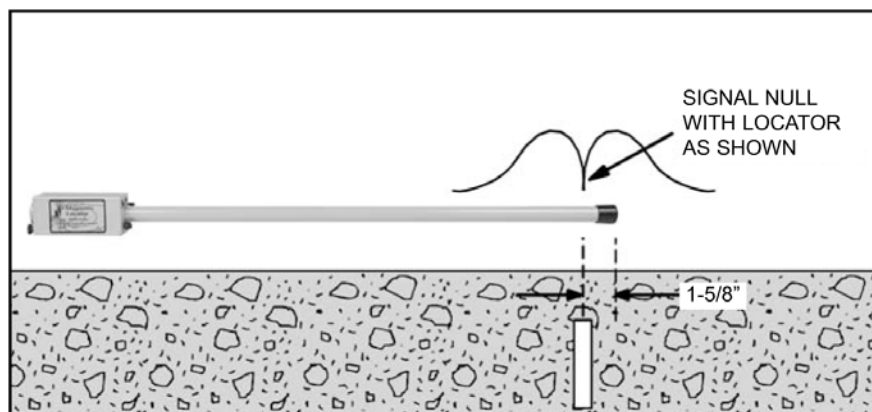

Figure 14: Placement of Locator While Searching Along a Chain Link Fence

Locating Valve Boxes

Both the valve and its casing, when iron, provide strong magnetic fields that make them easy to locate. Plastic enclosures containing magnets are easily located at depths of 10 feet or more.

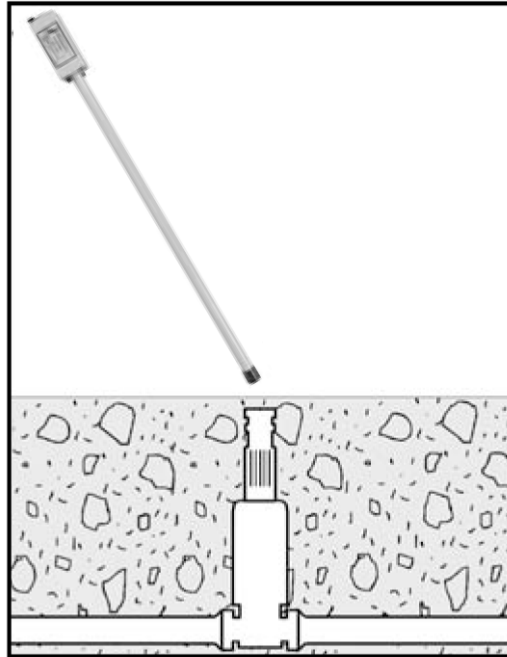

Figure 15: Locating Valve Boxes and Casings

Locating Cast-Iron Pipes

As illustrated in Figure 16, cast-iron pipes produce the strongest magnetic signals at their joints.

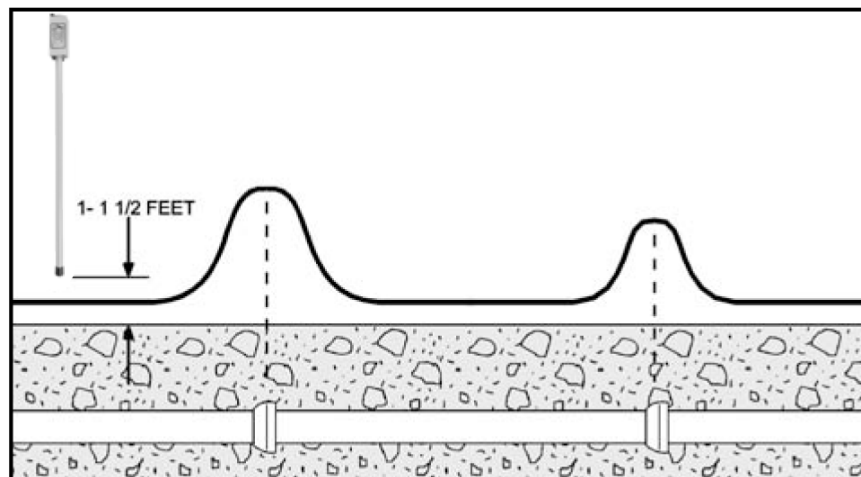

Figure 16: Signal Patterns Provided by Cast-Iron Pipes

After an initial sweep search identifies the general direction of the pipe, the steel pipe joints or transition points can be more accurately traced by the following procedure:

1. Set the sensitivity control to maximum.
2. Hold the locator vertically approximately 1 to 1-1/2 feet above the surface.
3. Walk without turning or tilting the locator.
4. Mark the locations where the maximum signal levels occur.
5. Return to an area of maximum signal strength and hold the locator several inches above the surface. The sensitivity will probably have to be reduced during this second pass. Four-inch pipes can be located at depths of up to 10 feet.

Locating Steel Drums

As shown in Figure 17, the GA-52Cx's signal pattern will vary depending on the vertical or horizontal orientation of the drum and how deep it is buried. A 55 gallon drum can be located at depths of up to 10 feet.

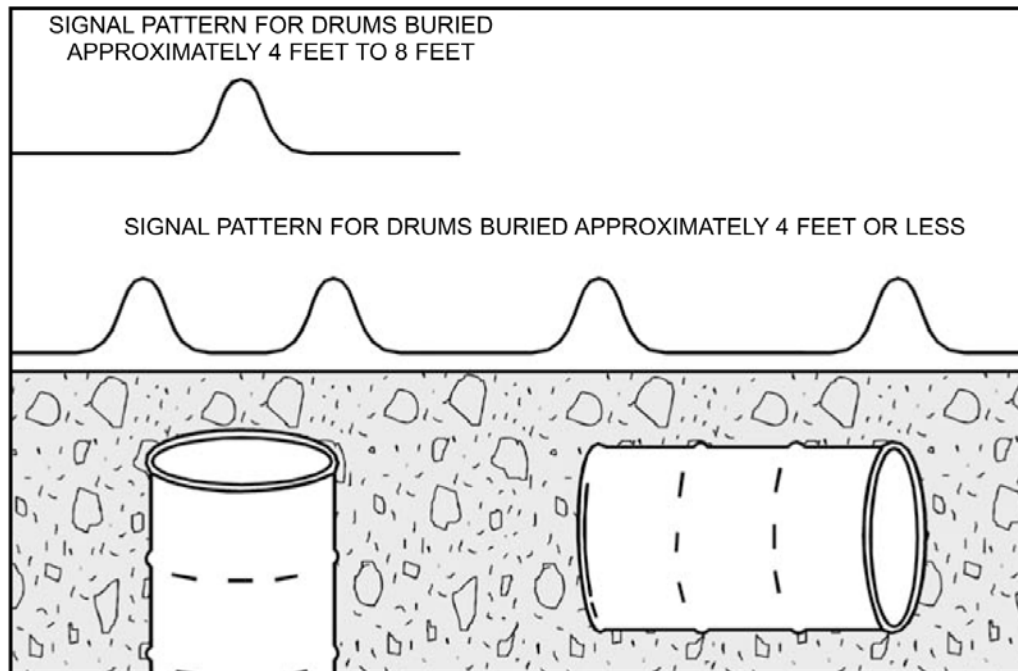

Figure 17: Signal Patterns Provided by Steel Drums

Additional Applications

1. The military and many local and state police departments use the GA-52Cx to detect buried ordnance and discarded weapons.
2. People drilling in an area where hazardous materials might be encountered use the GA-52Cx to search the area prior to drilling. Other Schonstedt magnetometers are available that can be lowered down the hole for periodic checks as drilling progresses.

Other Notes

1. A burbling sound indicates the presence of an energized power line.
2. The instrument will not detect non-ferrous metals, such as gold, silver, copper, brass and aluminum.

SECTION III: MAINTENANCE

The GA-52Cx is designed and built to give trouble-free operation. Normally, maintenance is limited to the occasional replacement of batteries. In the event that a malfunction does occur, refer to the Troubleshooting Guide. The guide lists a few problems that can generally be corrected in the field so that you can continue using the locator without interruption.

Replacement of Batteries

The GA-52Cx is powered by two alkaline 9-Volt batteries. Alkaline or lithium batteries may be used; however, lithium batteries are recommended (due to their exceptional performance). Lithium battery manufacturers advertise a 10 year shelf life (two to four times the operational life of an alkaline battery), and they advertise being environmentally safe. If battery leakage does occur, lithium batteries do not cause as severe of damage to the unit as alkaline batteries would.

As illustrated in Figure 18, the batteries are carried in the battery holder. Access to the batteries is obtained by removing the two knurled nuts and sliding off the cover. Always replace both batteries.

NOTE: When replacing the batteries hold the instrument by the metal chassis to avoid any contact with the printed circuit board and its components.

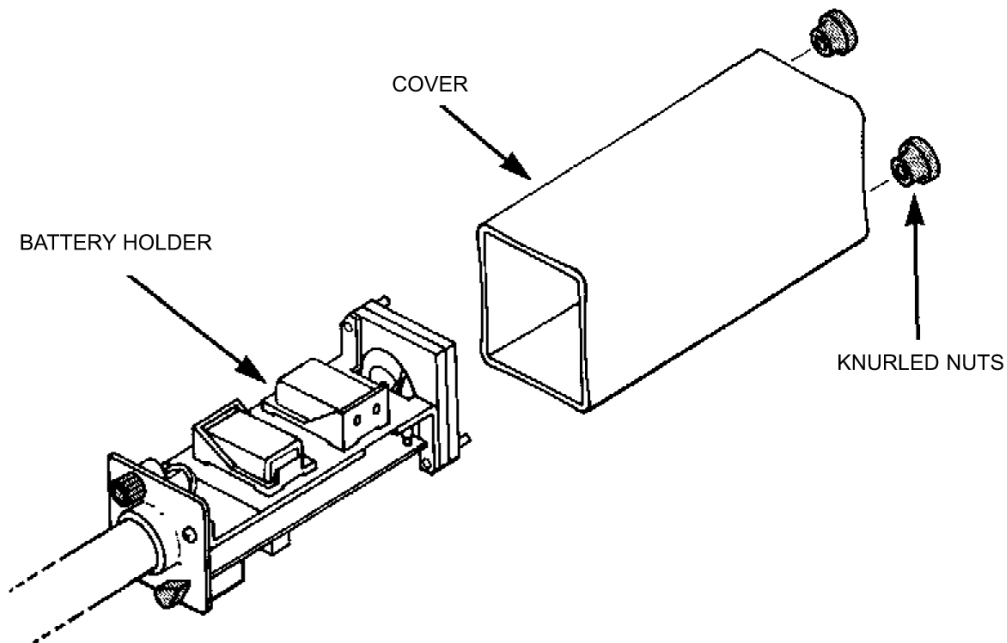

Figure 18: Exploded View of the Electronics Unit Cover

Troubleshooting Guide

Symptom	Possible Cause	How to Check	How to Fix
Dead	Dead Batteries	Replace	-----
	Batteries not making contact	Check for contact corrosion	Clean contacts
	Battery leakage	Remove	Return unit to factory
Intermittent	Batteries not making good contact	Check for corrosion	Clean contacts
Uncontrollable screaming	Weak batteries	Replace	-----

SECTION IV: SERVICE INFORMATION

If your locator needs service, please return it to the factory (in its case) with the following information: Name, Address, Telephone and Fax Numbers, Email Address, Where Purchased, Date of Purchase, and Description of Problem(s). An estimate will be provided prior to service work being done. See shipping information below:

For Service or Repair
Please ship locator (in its case) to:

Schonstedt Instrument Company
100 Edmond Road
Kearneysville, WV 25430

SECTION V: SPECIFICATIONS

(Specifications subject to change without notice.)

Input Power	Supplied by two alkaline 9-V batteries
Battery Life	40 hours (Intermittent usage)
Output	Approximately 40 Hz idle tone in speaker. Tone frequency increases (or decreases) with gradient-field intensity.
Weight	Approximately 2.5 lbs. (1.13 kg)
Operating Temperature	-13° F to 140° F (-25° C to 60° C)
Overall Length	42-5/16 in (107.4cm)
Waterproof Length	34-1/2 in. (87.6 cm)
Nominal Sensor Spacing	20 in. (50.8 cm)
Construction	Rugged, modular all solid state

SECTION VI: PARTS DIAGRAM

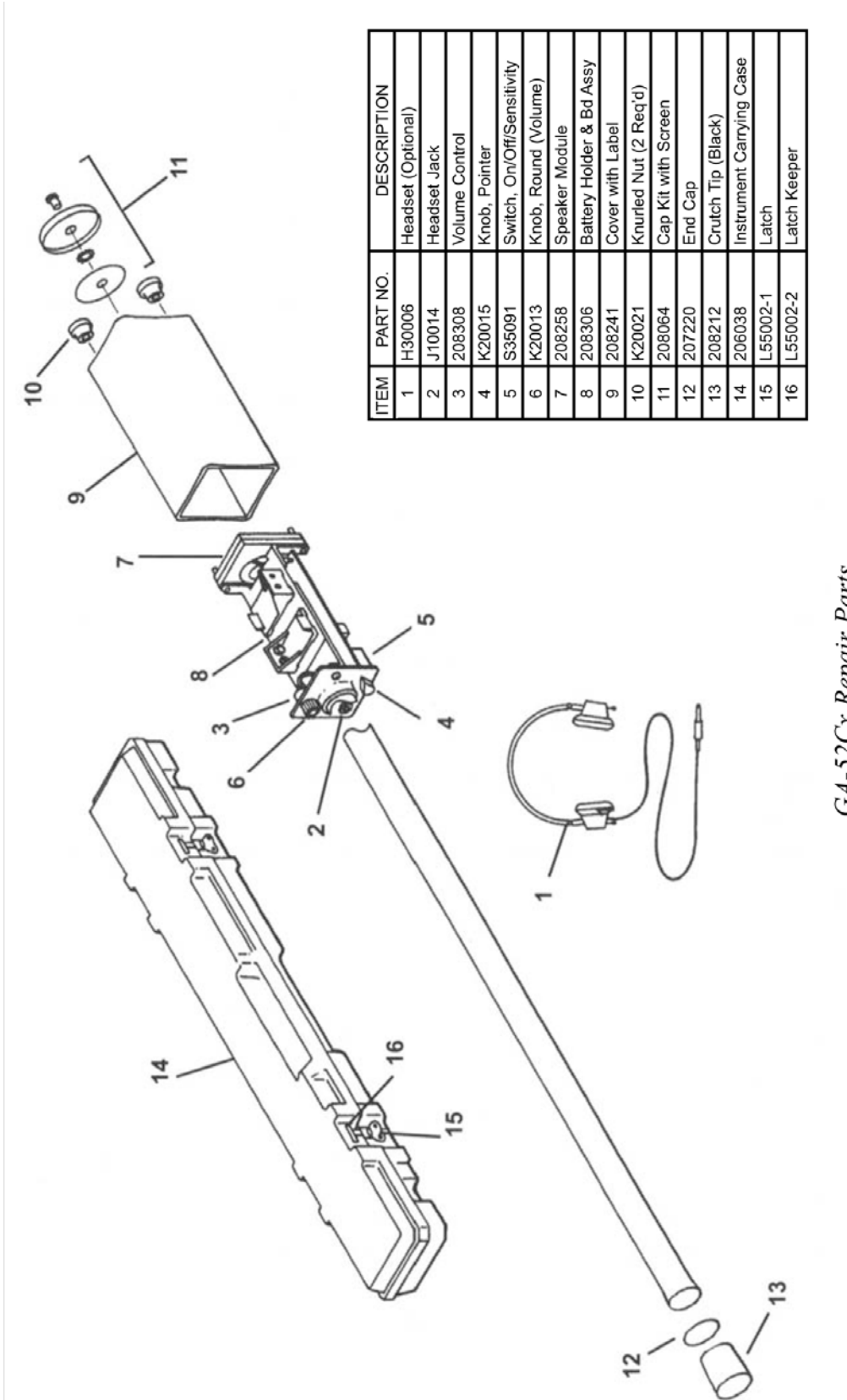

ITEM	PART NO.	DESCRIPTION
1	H30006	Headset (Optional)
2	J10014	Headset Jack
3	208308	Volume Control
4	K20015	Knob, Pointer
5	S35091	Switch, On/Off/Sensitivity
6	K20013	Knob, Round (Volume)
7	208258	Speaker Module
8	208306	Battery Holder & Bd Assy
9	208241	Cover with Label
10	K20021	Knurled Nut (2 Req'd)
11	208064	Cap Kit with Screen
12	207220	End Cap
13	208212	Crutch Tip (Black)
14	206038	Instrument Carrying Case
15	L55002-1	Latch
16	L55002-2	Latch Keeper

GA-52Cx Repair Parts

SECTION VII: LIMITED WARRANTY

Schonstedt Instrument Company (Schonstedt) warrants each product of its manufacture to be free from defects in material and workmanship subject to the following terms and conditions. The warranty is effective for 7 years* after the shipment by Schonstedt to the original purchaser. Please complete the warranty registration card and send back to Schonstedt Instrument Company.

Schonstedt's obligation under the warranty is limited to servicing or adjusting any product returned to the factory for this purpose and to replacing any defective part thereof. Such product must be returned by the original purchaser, transportation charges prepaid, with a description of the defect in writing. If the fault has been caused by misuse or abnormal conditions of operation, repairs will be billed. Specifically, this warranty does not cover product that has been subject to inundation by fire, water or other liquid intrusion, or units that have been damaged or compromised due to repair, alteration or modification by anyone other than an authorized repair representative. Prior to a repair being performed by Schonstedt, a cost estimate will be submitted and no work will be completed until authorized by the customer. Batteries are specifically excluded under the warranty and should be addressed to the manufacturer of batteries in question.

Schonstedt shall not be liable for any injury to persons or property or for any other special or consequential damages sustained or expenses incurred by reason of the use of any Schonstedt product.

* For Military & EOD applications, the warranty is 1 year.



This device complies with part 15 of the FCC Rules. Operation is subject to the following two conditions: (1) this device may not cause harmful interference, and (2) this device must accept any interference received, including interference that may cause undesired operation.



Application of Council Directive(s):
2004/108/EC

Standard(s) to which Conformity is Declared:
EN 61000-6-1:2001, EN61000-4-2, EN61000-4-3, EN 61000-6-3:2004,
EN55022:1998 with Amendment A1:2000 (CISPR-22)